



The Dolomite Centre Ltd.
 Unit 1, Anglian Business Park, Orchard Road,
 Royston, Hertfordshire, SG8 5TW, UK
T: +44 (0)1763 242491
F: +44 (0)1763 246125
E: dolomitesales@syrris.com
W: www.dolomite-centre.com

The Dolomite Centre Limited
 Registered office: 27 Jarman Way,
 Royston, Hertfordshire, SG8 5HW, UK
 Company No. 05640084

INFORMATION SHEET

Part name	Mitos Y-junction chip	Part number	3200008
-----------	-----------------------	-------------	---------

Description

The Mitos Y-Junction Chip is a glass microfluidic device designed for a range of applications including Liquid-liquid contacting and observation of molecular diffusion between parallel laminar flow streams. The chip is designed to fit into the mitos chip holder H (part number 3000155) with two Mitos Edge Connectors (part number 3000024).



Left: Mitos Y-junction chip

Below: Y-junction chip in mitos chip holder H (3000155) with edge connectors

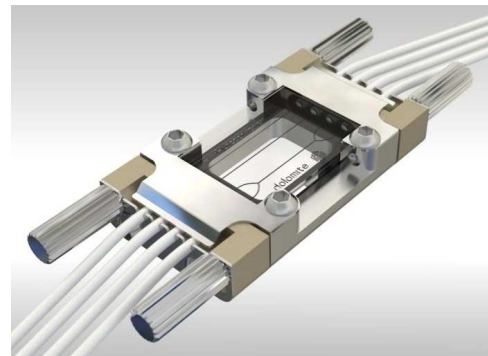

Benefits

- Extremely smooth channel surface
- Wide temperature and pressure range
- Excellent chemical compatibility
- Quick connect/disconnect
- High visibility (excellent access for optics)
- Compact
- Low cost

	Chip Specification	Value
1	Number of inputs	4
2	Number of outputs	4
3	Internal channel cross-section	100 µm x 205 µm (depth x width)
4	Channel length between Y-junctions	12.5 mm
5	Volume of channel after Y-junction	2.5 µl
6	Chip size (L x W x H)	22.5 mm x 15.0 mm x 4mm
7	Chip top layer thickness	2.0 mm
8	Chip base layer thickness	2.0 mm
9	Operating pressure	30 Bar with edge connector (higher with other connection methods)
10	Operating temperature	260° C with edge connector
11	Material	Glass
12	Fabrication process	HF etching and thermal bonding

Channel geometry

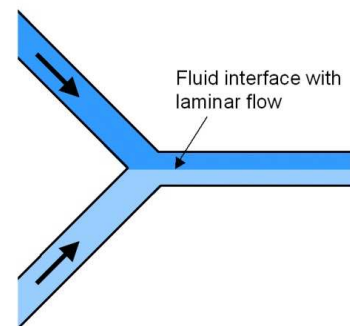
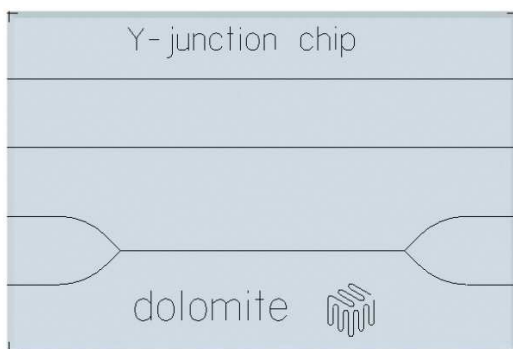
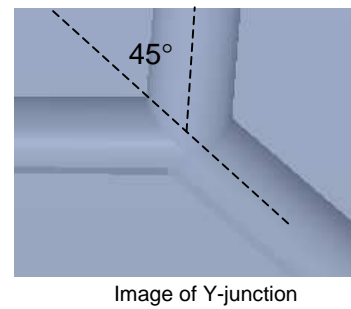
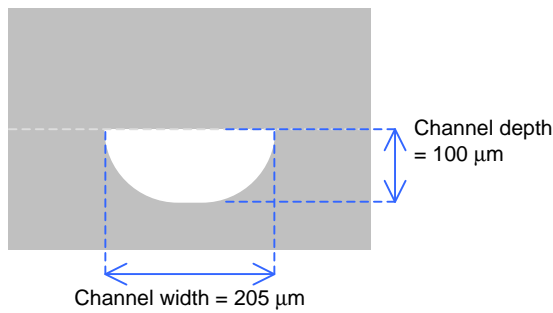

Custom options

The channel may be etched to different depths, for example from 50 μm x 105 μm up to 350 μm x 705 μm (depth x width). The top layer can also be etched giving a circular channel cross-section.

Custom channel layouts can also be specified.

Custom surface coatings

The glass channel surface is naturally hydrophilic. The chip can also be supplied with:

- Hydrophobic coating on channel surfaces
- Platinum or gold coating on channel surfaces

Edge connector geometry

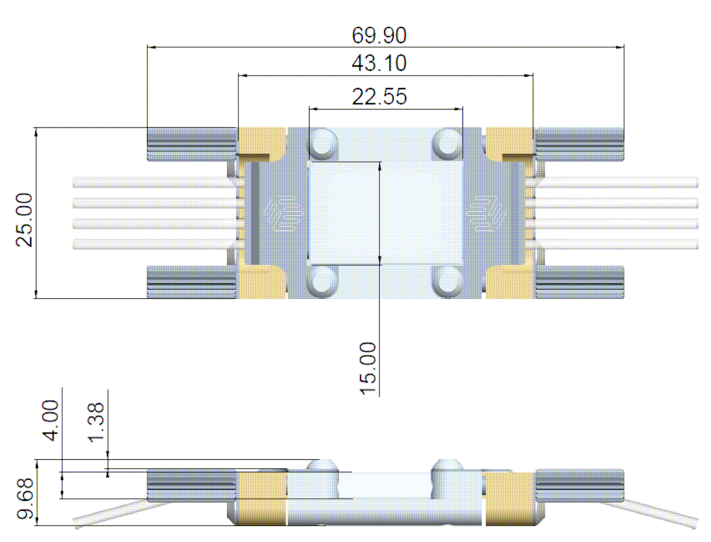

Optical transmission

